

A - Parts List

Confidential and Proprietary

Bed Frame - x1

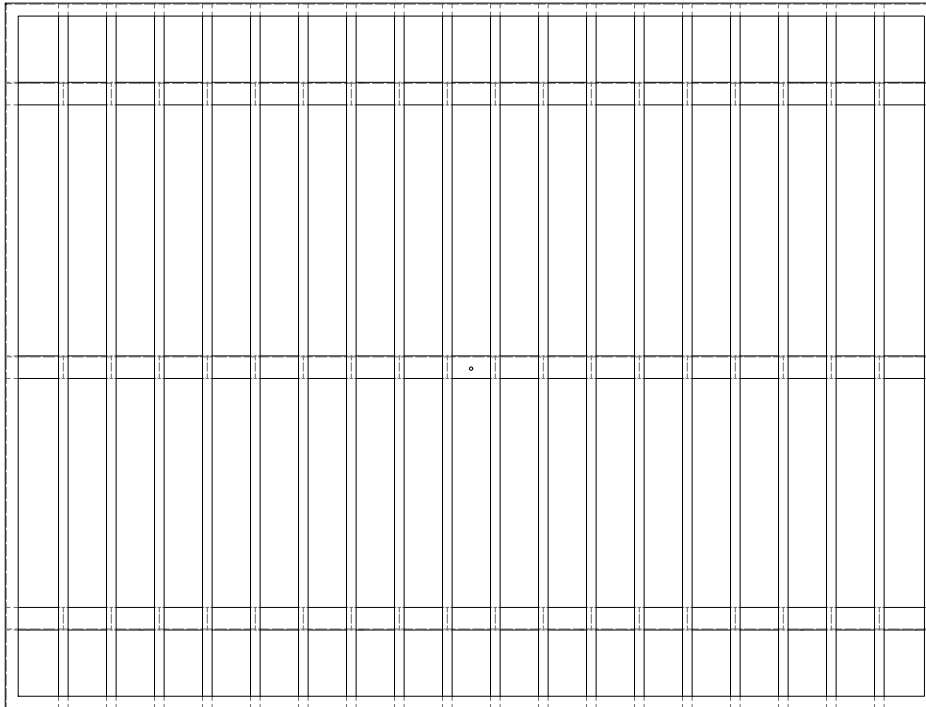

**X16 - 1/4"-20 x 1 1/4"L
Black Bolt**



X16 - 5/16" Black Washer



X16 - 1/4"- 20 Hex Nut



**X8 - #8 x 1 1/4"L
Black Flat Phil**



Side Panel - x2 - G1S

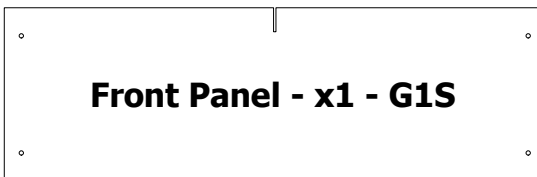

Front Panel - x1 - G1S

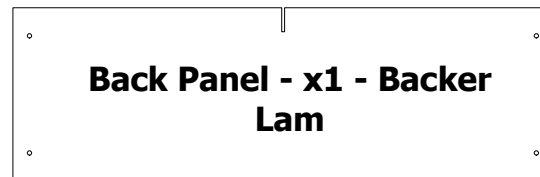

**Back Panel - x1 - Backer
Lam**

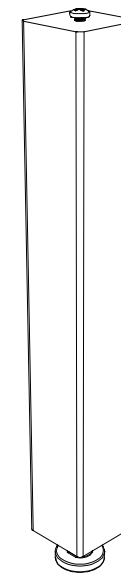

**Center Leg
X1**

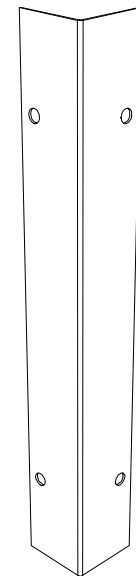

**Cornet Brace
X4**

MATERIALS:
- HP-Laminate PB-5/8"
- 0.018 Edge Tape
- Nail Glides
- Metal Bed Frame
- Metal Corner Brackets
- Metal Center Leg W/Leveler

COMMENTS:
- **Overall:**
- **Color:** Wilsonart - 0000 - Custom Laminate
Black Metal - Powder Coated Paint
- **Note:**

SIZE
A

DWG. NO.

AHB 5700XX 5BB - 5700 - Queen Bed Base (INST).dwg

Quantity:

00

Revision Date:

11/19/2018

Note: Design and Drawings are Property of Dickson Furniture Manufacturers LLC and may not be duplicated or reproduced without the express written consent of Dickson Furniture Manufacturers LLC

Sheet:
1 of 6

B - Parts Lyout

Confidential and Proprietary

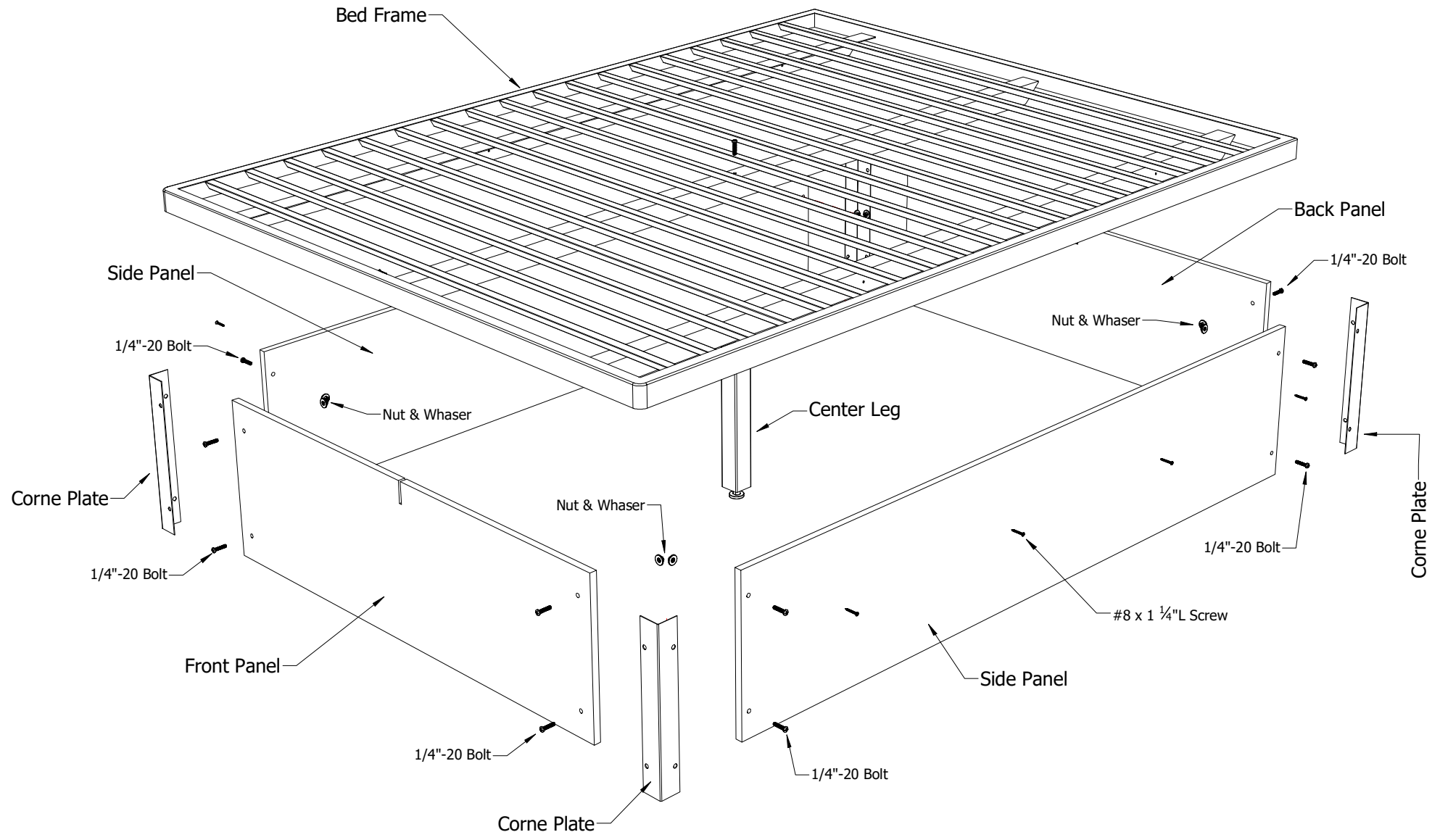

<p>MATERIALS:</p> <ul style="list-style-type: none"> - HP-Laminate PB-5/8" - 0.018 Edge Tape - Nail Glides - Metal Bed Frame - Metal Corner Brackets - Metal Center Leg W/Leveler 	<p>COMMENTS:</p> <ul style="list-style-type: none"> - Overall: - Color: Wilsonart - 0000 - Custom Laminate Black Metal - Powder Coated Paint - Note: 	<p>SIZE</p> <p>A</p>	<p>DWG. NO.</p> <p>AHB 5700XX 5BB - 5700 - Queen Bed Base (INST).dwg</p> <p>Revision Date:</p> <p>11/19/2018</p> <p>Note: Design and Drawings are Property of Dickson Furniture Manufacturers LLC and may not be duplicated or reproduced without the express written consent of Dickson Furniture Manufacturers LLC</p>	<p>Quantity:</p> <p>00</p> <p>Sheet:</p> <p>2 of 6</p>
--	---	------------------------------------	--	---

Step #1

Place and align the panels as shown below with the color side facing out. Note that the side panel will be placed between the front and back panel, and the color side of the side panel will be flush with the edge of the front and back panels.

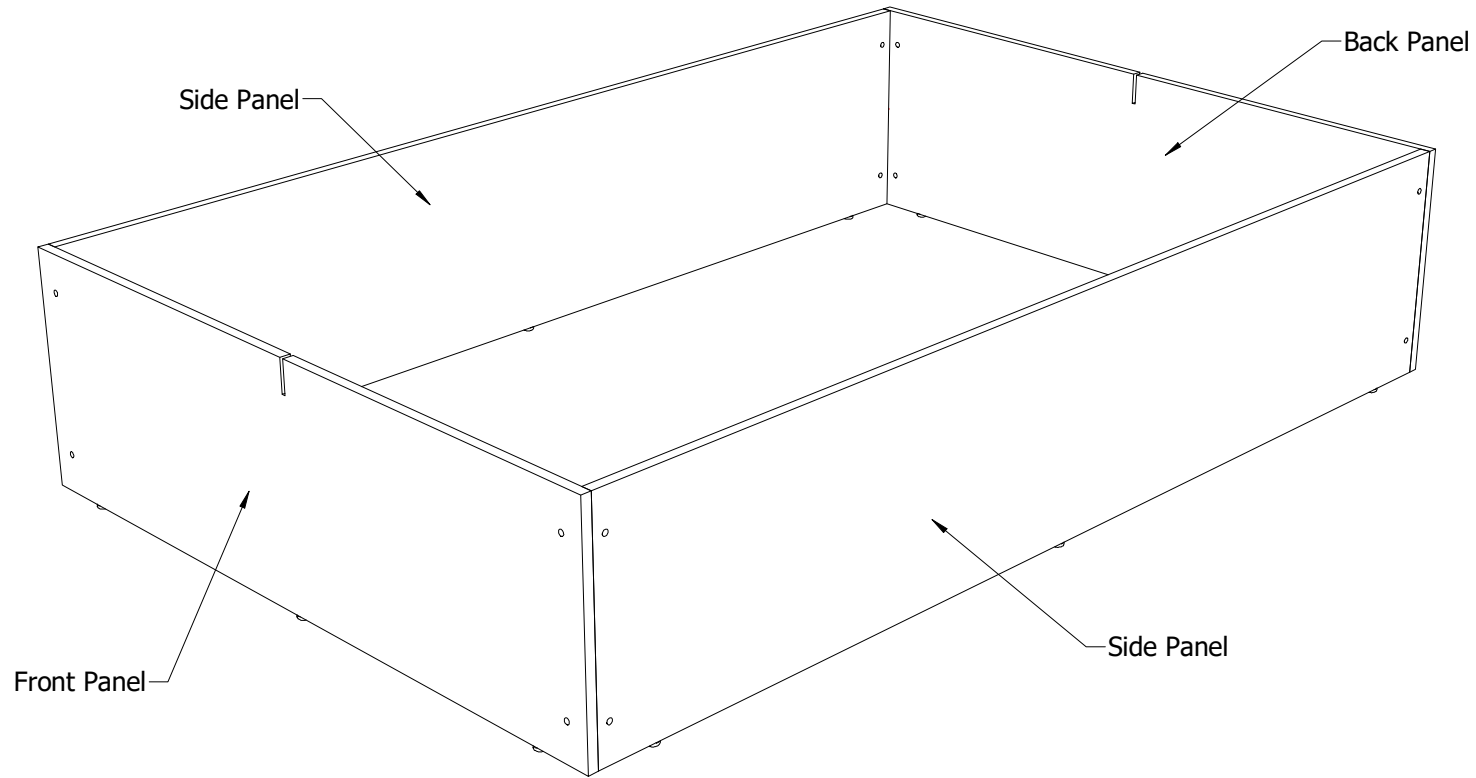

NOTE: Back panel will be laminated with “backer laminate” on both sides, and front panel will have the color selected by the client on one side, and “backer laminate” on the opposite side.

<p>MATERIALS:</p> <ul style="list-style-type: none"> - HP-Laminate PB-5/8" - 0.018 Edge Tape - Nail Glides - Metal Bed Frame - Metal Corner Brackets - Metal Center Leg W/Leveler 	<p>COMMENTS:</p> <ul style="list-style-type: none"> - Overall: - Color: Wilsonart - 0000 - Custom Laminate Black Metal - Powder Coated Paint - Note: 	<p>SIZE</p> <p>A</p>	<p>DWG. NO.</p> <p>AHB 5700XX 5BB - 5700 - Queen Bed Base (INST).dwg</p> <p>Revision Date:</p> <p>11/19/2018</p>	<p>Quantity:</p> <p>00</p> <p>Note: Design and Drawings are Property of Dickson Furniture Manufacturers LLC and may not be duplicated or reproduced without the express written consent of Dickson Furniture Manufacturers LLC</p>	<p>Sheet:</p> <p>3 of 6</p>
--	---	------------------------------------	---	---	-----------------------------

Step #2

Place the corner bracket on each corner of the bed base. Using the 1/4"-20 Pan head bolt, washers and nut, secure the bracket to the base. The nut and washer will go on the inside face of the bed base.

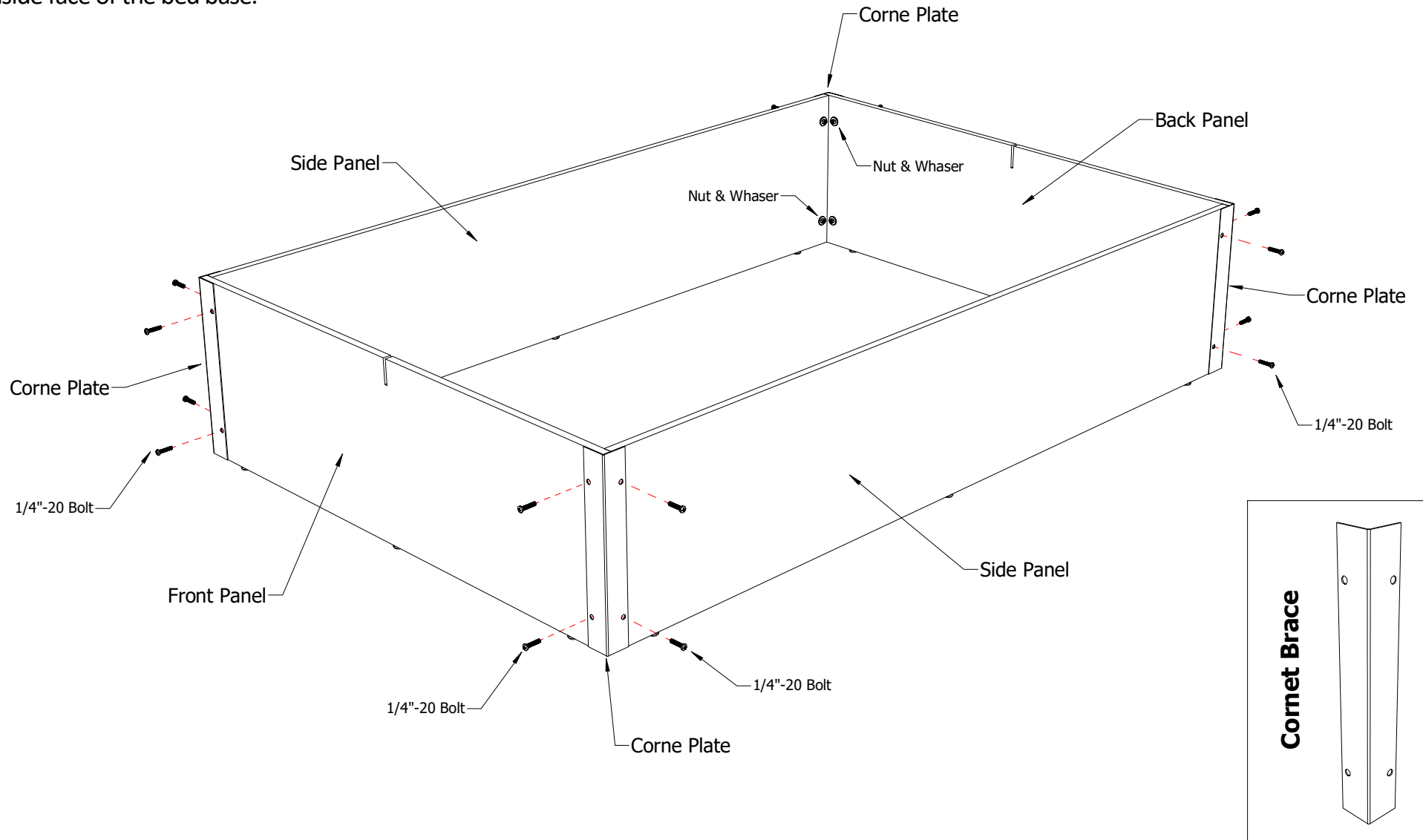

MATERIALS:
 - HP-Laminate PB-5/8"
 - 0.018 Edge Tape
 - Nail Glides
 - Metal Bed Frame
 - Metal Corner Brackets
 - Metal Center Leg W/Leveler

COMMENTS:
 - **Overall:**
 - **Color:** Wilsonart - 0000 - Custom Laminate
 Black Metal - Powder Coated Paint
 - **Note:**

SIZE
A

DWG. NO.

AHB 5700XX 5BB - 5700 - Queen Bed Base (INST).dwg

Quantity:

00

Revision Date:

11/19/2018

Note: Design and Drawings are Property of Dickson Furniture Manufacturers LLC and may not be duplicated or reproduced without the express written consent of Dickson Furniture Manufacturers LLC

Sheet:
 4 of 6

Step #3

Place bed frame on top of the bed base. Align bed base between the two side rails under the bed frame and place the back of the bed base against the back edge of the bed frame. Then, using the #8 x 1-1/4" wood screws provided on the box, secure the bed base to the top frame.

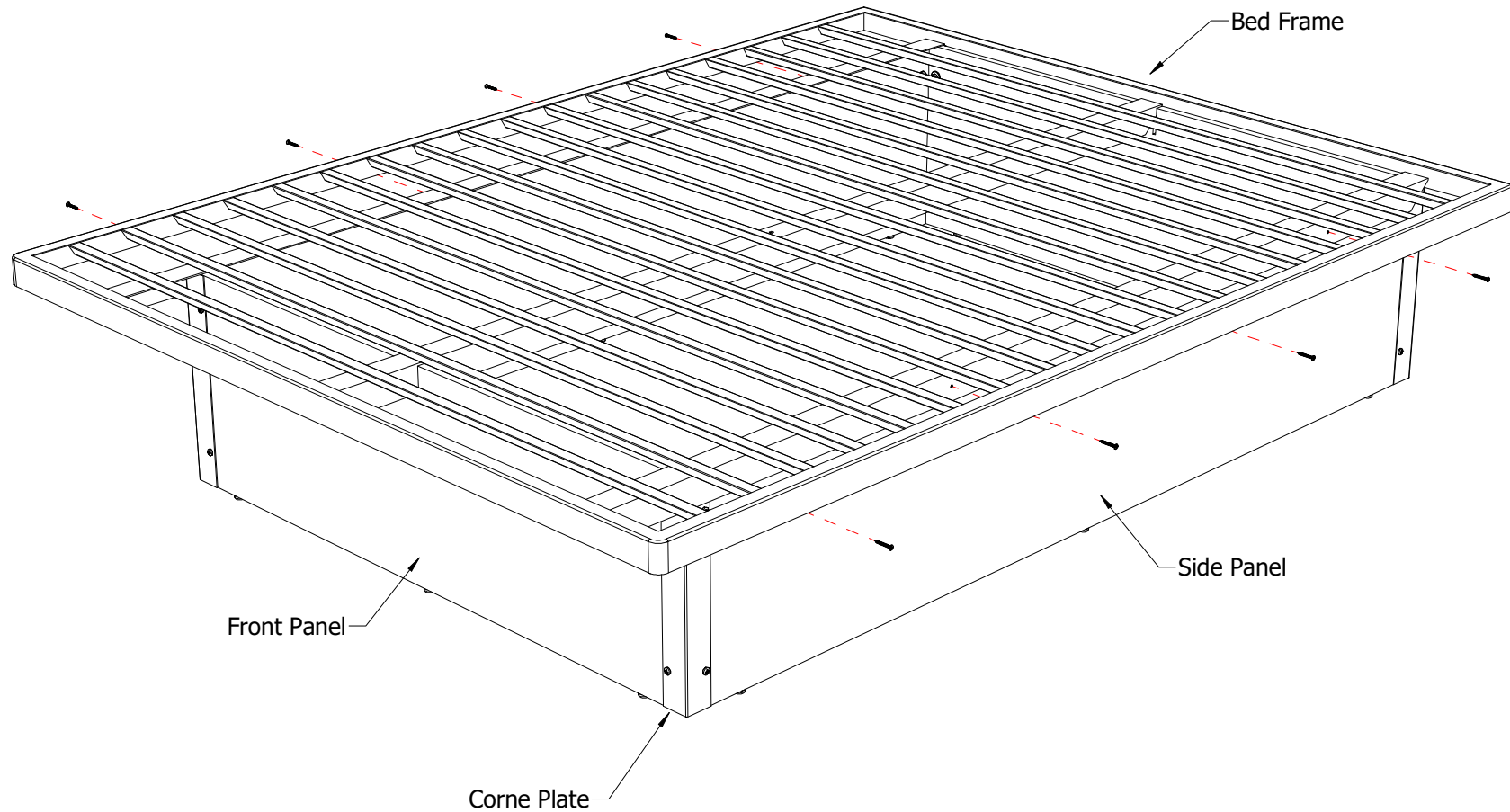

NOTE: If you consider this option easier, you can do this step with the bed frame upside down on the floor and placing the bed base on top of the frame and secure them with the screws provided.

MATERIALS:
 - HP-Laminate PB-5/8"
 - 0.018 Edge Tape
 - Nail Glides
 - Metal Bed Frame
 - Metal Corner Brackets
 - Metal Center Leg W/Leveler

COMMENTS:
 - **Overall:**
 - **Color:** Wilsonart - 0000 - Custom Laminate
 Black Metal - Powder Coated Paint
 - **Note:**

SIZE
A

DWG. NO.

AHB 5700XX 5BB - 5700 - Queen Bed Base (INST).dwg

Quantity:

00

Revision Date:

11/19/2018

Note: Design and Drawings are Property of Dickson Furniture Manufacturers LLC and may not be duplicated or reproduced without the express written consent of Dickson Furniture Manufacturers LLC

Sheet:
 5 of 6

Step #4

Place center leg under the bed frame and secure it with the "5/16"-18" bolt provided with the leg on the hole locator in the center of the bed frame rail.

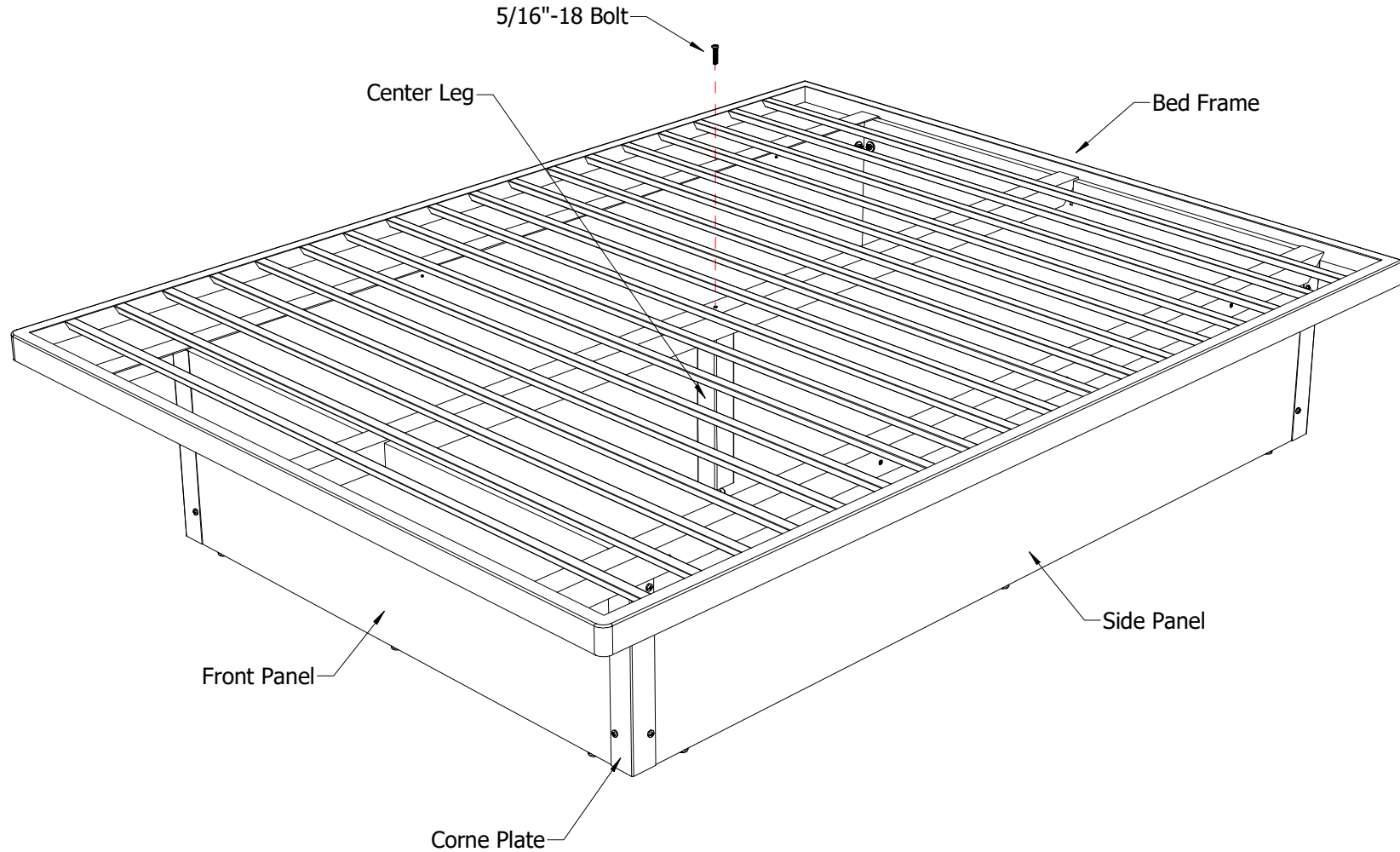

MATERIALS:
 - HP-Laminate PB-5/8"
 - 0.018 Edge Tape
 - Nail Glides
 - Metal Bed Frame
 - Metal Corner Brackets
 - Metal Center Leg W/Leveler
 -

COMMENTS:
 - **Overall:**
 - **Color:** Wilsonart - 0000 - Custom Laminate
 Black Metal - Powder Coated Paint
 - **Note:**

SIZE
A

DWG. NO.

AHB 5700XX 5BB - 5700 - Queen Bed Base (INST).dwg

Quantity:

00

Revision Date:

11/19/2018

Note: Design and Drawings are Property of Dickson Furniture Manufacturers LLC and may not be duplicated or reproduced without the express written consent of Dickson Furniture Manufacturers LLC

Sheet:
 6 of 6